

**NOTE:** Strip length is 4.75 mm [.197 in.] for wire size range 30–14; and 6.35 mm [.250 in.] for 12–10 wire size range.

WIRE		UNIVERSAL MATE-N-LOK CONTACTS				HAND TOOLING (Instruction Sheet)
SIZE (AWG)	INSULATION DIAMETER	LOOSE PIECE		STRIP		
		PIN	SOCKET	PIN	SOCKET	
30 to 26	0.81–1.45 [.032–.057]	770672-[ ]	770673-[ ]	350924-[ ]	350925-[ ]	58439-[ ] (408-9591)
24 to 18	1.02–2.54 [.040–.100]	350690-[ ]	350689-[ ]●	350561-[ ]	350570-[ ]●	91510-1 (408-9479)
		350690-[ ]	640347-[ ]	350561-[ ]	350851-[ ]	
		350706-[ ]■	—	350699-[ ]■	—	
20 to 14	1.52–3.30 [.060–.130]	350547-[ ]	350550-[ ]	350218-[ ]	350536-[ ]	91500-1 (408-9476)
		350705-[ ]■	—	350687-[ ]■	—	
		350669-[ ]†	—	350654-[ ]†	—	
	3.30–5.08 [.130 to .200]	350552-[ ]	350551-[ ]	350538-[ ]	350537-[ ]	91508-1●● (408-8547) 91506-1●● (408-8547)
350707-[ ]■		—	350700-[ ]■	—		
18 to 14	3.30–5.08 [.130 to .200]	350918-[ ]	350919-[ ]	350873-[ ]	350874-[ ]	91508-1 (408-8547) 91506-1 (408-8547)
12 to 10	5.08 [.200] Max.	640309-[ ]	640310-[ ]	350922-[ ]	350923-[ ]	69710-1●● (408-2095) w/ Die 58380-[ ]

- Stock thickness 0.25 mm [.010 in.]; all others 0.30 mm [.012 in.].
- Split pin contact.
- Hand Tool 91508-1 for wire size 20–18 AWG. Hand Tool 91506-1 for wire size 16–14. Hand Tool 69710-1 uses Die Set 58380-1 for 12 AWG and 58380-2 for 10 AWG.
- † Grounding pin.

Figure 1

## 1. INTRODUCTION

This instruction sheet covers the use of the MATE-N-LOK contact and housing selection charts.

Read these instructions thoroughly to be sure the selected contacts are compatible with the specified housings, and the selected wire and application tooling are compatible with the contacts.

The MATE-N-LOK contacts and housings are divided into three categories: Universal, Commercial,

and .140. The contacts must be installed into their appropriate housings and not switched between various categories.



**NOTE** All dimensions in this document are in millimeters [with inches in brackets]. Figures and Illustrations are for reference only and are not drawn to scale.

Reasons for reissue of this document are provided in Section 7, REVISION SUMMARY.

**2. CONTACT DESCRIPTION**

**2.1. Universal Contacts** (Figure 1)

Pin and socket contacts are available in five different wire ranges, covering wire sizes from 30 to 10 AWG, with an insulation diameter range of 0.81 – 5.08 mm [.032 – .200 in.].

Loose-piece contacts are designed for hand tool or pneumatic tool applications. Strip contacts are terminated using miniature quick-change applicators in the AMP-O-ELECTRIC\* Machine, AMPOMATOR\* Automatic Lead-Making Machine, and the Standard and Mini-Single End Lead Machine (SELM and Mini-SELM). Consult your local Tyco Electronics Representative for assistance in selecting the machine and applicator that will best suit your needs.

**2.2. Commercial Contacts** (Figure 2)

Pin and socket commercial contacts are available in loose-piece or strip form. Loose-piece contacts are designed for hand tool or pneumatic tool applications.

Strip contacts are terminated using miniature quick-change applicators in the AMP-O-ELECTRIC Machine, AMPOMATOR Automatic Lead-Making Machine, and the Standard and Mini-Single End Lead Machine (SELM and Mini-SELM). Commercial contacts are available for terminating wire from 30 to 14 AWG.

**2.3. .140 MATE-N-LOK Contacts** (Figure 3)

Pin and socket .140 contacts feature a stabilizing barrel and are available in loose piece and strip form. The contacts are available for terminating wire from 20 to 10 AWG.

Strip contacts are crimped by miniature quick-change applicators in the AMP-O-ELECTRIC Machine, AMPOMATOR Automatic Lead-Making Machine, and the Standard and Mini-Single End Lead Machine (SELM and Mini-SELM). Loose-piece contacts are crimped with hand tools.

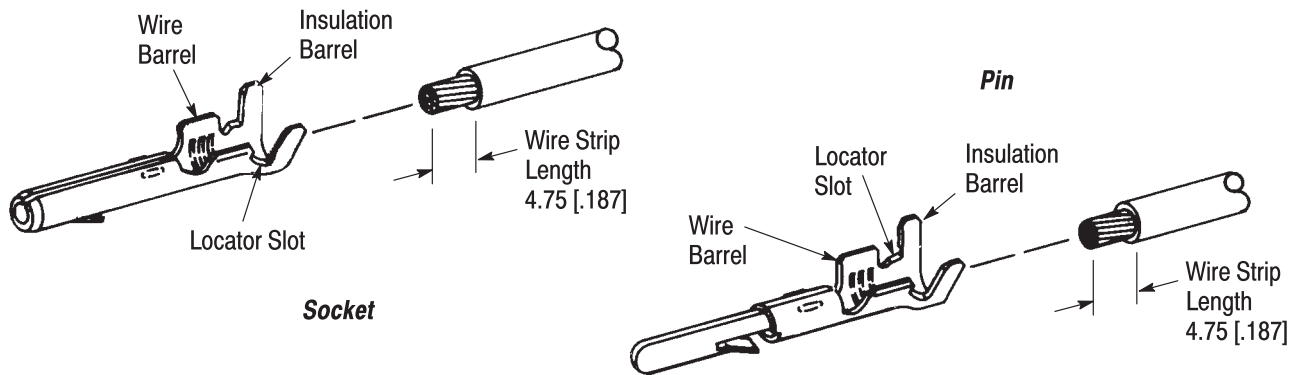

WIRE		COMMERCIAL MATE-N-LOK CONTACTS				HAND TOOLING (408-8547)
SIZE (AWG)	INSULATION DIAMETER	LOOSE PIECE		STRIP		
		PIN	SOCKET	PIN	SOCKET	
30 to 22	1.91 [.075] (Max.)	61174-[]	61173-[]	350079-[]	350078-[]	91515-1
24 to 18	1.09-1.91 [.043-.075]	60618-[]	60617-[]	61116-[]	61314-[]	91528-1
24 to 20	1.52-2.54 [.060-.100]	60618-[]	60617-[]	61116-[]	61314-[]	91512-1
		—	61473-[]	—	61115-[]	
20 to 14	2.54-3.30 [.100 to .130]	60620-[]	60619-[]	61118-[]	61117-[]	91504-1
(1) 18 and (1) 16, or (2) 18	†2.92 [.115] (Max.) and 3.30 [.130] (Max.)	350639-[]	350638-[]	350558-[]	350557-[]	91504-1

†2.92 mm [.115 in.] max. each for applicator terminations. 3.30 mm [.130 in.] max. combined for hand tool terminations.

Figure 2

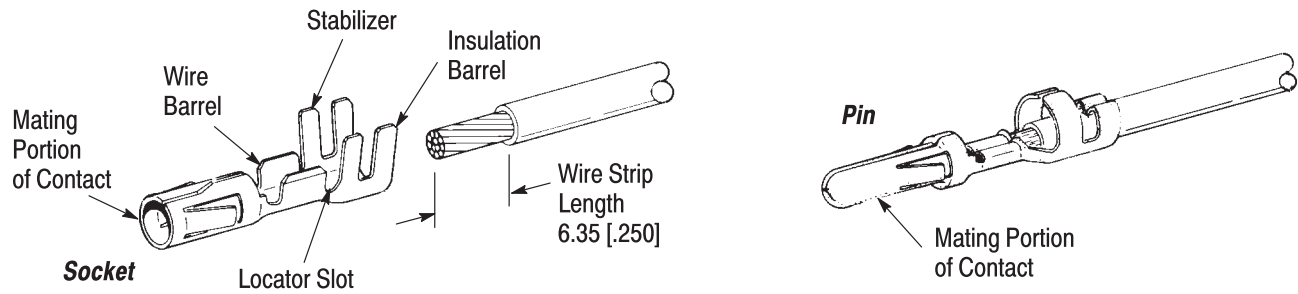

WIRE		.140 MATE-N-LOK CONTACTS				HAND TOOLING (Instruction Sheet)
SIZE (AWG)	INSULATION DIAMETER	LOOSE PIECE		STRIP		
		PIN	SOCKET	PIN	SOCKET	
20 to 14	2.54-4.57 [.100-.180]	350389-[]	350388-[]	61627-[]	61626-[]	90247-1 (408-7434)
14 to 10		350391-[]	350390-[]	350201-[]	350200-[]	69710-1 (408-2095) w/ Die 58373-[] or 58374-[]

Figure 3



UNIVERSAL MATE-N-LOK HOUSINGS

NUMBER OF CIRCUITS	CAP	PLUG	HOUSING COLOR●	NUMBER OF CIRCUITS	CAP	PLUG	HOUSING COLOR●
1	770421-1	350867-[]	NAT	8	—	640586-[]	NAT
	350866-[]	350865-[]	WHT		—	640582-[]	WHT
2	480699-[]	480698-[]	NAT	9	480707-[]	480706-[]	NAT
	350778-[]	350777-[]	WHT		350782-[]	350720-[]	WHT
3	480701-[]	480700-[]	NAT	12	480709-[]	480708-[]	NAT
	350767-[]	350766-[]	WHT		350783-[]	350735-[]	WHT
4	480703-[]	480702-[]	NAT	15	480711-[]	480710-[]	NAT
	350780-[]	350779-[]	WHT		350784-[]	350736-[]	WHT
5	480764-[]	480763-[]	NAT				
	350810-[]	350809-[]	WHT				
6	480705-[]	480704-[]	NAT				
	350781-[]	350715-[]	WHT				
	—	640585-[]	NAT				
	—	640581-[]	WHT				

- Natural colored housings (indicated as NAT on this sheet) are 94V-2 nylon material. White colored housings (indicated as WHT on this sheet) are flame-retardant 94V-0 nylon material.

Figure 4

**3. HOUSINGS** (Figures 4, 5, and 6)

Determine the housing type to be assembled. Refer to the listings of compatible contacts and select the desired contact type and recommended size.

*Commercial* – Housings have a temperature rating of  $-55^{\circ}\text{C}$  to  $+105^{\circ}\text{C}$  [ $-65^{\circ}\text{F}$  to  $221^{\circ}\text{F}$ ] and a maximum voltage/current rating of 250 Vac at 19 amperes per contact.

*Universal* – Housings have a temperature rating of  $-55^{\circ}\text{C}$  to  $+105^{\circ}\text{C}$  [ $-65^{\circ}\text{F}$  to  $221^{\circ}\text{F}$ ] and a maximum voltage/current rating of 600 Vac at 19 amperes per contact. Pin and socket contacts can be used in either plug or cap housings.

*.140* – Housings have a temperature rating of  $-55^{\circ}\text{C}$  to  $+105^{\circ}\text{C}$  [ $-65^{\circ}\text{F}$  to  $221^{\circ}\text{F}$ ] and a maximum voltage/current rating of 250 Vac at 28 amperes per contact.

**Plug**  
(Socket Housing)

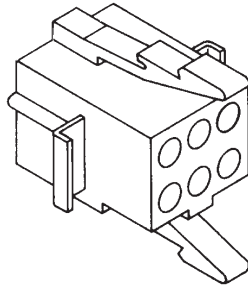

**Cap**  
(Pin Housing)

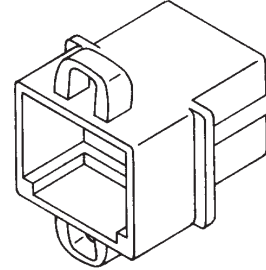

**COMMERCIAL MATE-N-LOK HOUSINGS**

NUMBER OF CIRCUITS	CAP	PLUG	NUMBER OF CIRCUITS	CAP	PLUG
1	480350-[]	480349-[]	8	480284-[]	480283-[]†
1	480351-[]	480349-[]	8	480345-[]	480283-[]†
2	480319-[]†	480318-[]†	9	480277-[]†	480274-[]†
3	480305-[]†	480303-[]†	10	480286-[]	480285-[]†
3	480305-[]†	480304-[]†	10	480339-[]	480285-[]†
4	480426-[]†	480424-[]†	12	480278-[]†	480275-[]†
4	480426-[]†	480425-[]†	12	480288-[]	480287-[]†
6	480271-[]	480270-[]†	15	480324-[]†	480323-[]†
6	480276-[]†	480273-[]†	16	480439-[]	480438-[]†
6	480340-[]	480270-[]†			
6	—	480270-[]†			

† Housing accepts double wire applications where individual insulation diameters do not exceed 2.92 [.115].

Figure 5

**Plug**  
(Socket Housing)

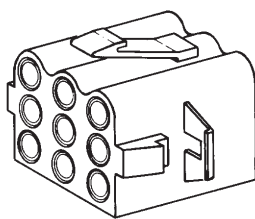

**Cap**  
(Pin Housing)

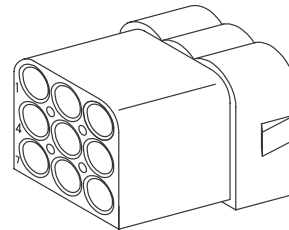

**.140 MATE-N-LOK HOUSINGS**

NUMBER OF CIRCUITS	CAP	PLUG	NUMBER OF CIRCUITS	CAP	PLUG
2	350345-[]	350344-[]	9	480586-[]	480585-[]
3	350347-[]	350346-[]	9	480673-[]	480672-[]
4	480512-[]	480510-[]			

Figure 6

#### 4. CONTACT SELECTIONS

Contact selections are made from the tables in Figures 1 through 3:

- Universal Contacts – Figure 1
- Commercial Contacts – Figure 2
- .140 Contacts – Figure 3

Select the contacts as follows:

1. Determine the appropriate wire size to be used with the contact according to column 1. Make certain the wire insulation diameter is within the range specified in column 2.
2. Columns 3, 4, 5, and 6 indicate appropriate loose–piece and strip form pin and socket contacts for the selected wire size. Check that these base part numbers correspond with those on package or reel.
3. Column 7 indicates the appropriate hand tooling to be used to crimp the loose–piece contacts.

#### 5. CONTACT INSERTION

Insertion Tool 91002–1 is recommended for inserting Universal MATE–N–LOK contacts; Insertion Tool 455830–1 is used with Commercial contacts. No insertion tool is recommended for the .140 MATE–N–LOK contacts because the contacts handle larger wire sizes.

To insert a contact, place the tweezer–shaped tool over the wire, with the tool insertion tips behind the contact insulation barrel. Insert the contact into the housing cavity until the contact locking lance is fully seated.

#### 6. CONTACT EXTRACTION

Extraction Tool 305183 and 465644 are designed for extracting commercial MATE–N–LOK contacts from their housings.

Extraction Tool 318845–1 is recommended for extracting contacts from .140 housings. In Universal MATE–N–LOK housings, use Extraction Tool 1804030–1 for removing contacts.

#### 7. REVISION SUMMARY

Since the previous release of this sheet, the following changes were made:

- Updated document to corporate requirements
- Deleted “Automotive” contacts and housings throughout document
- Deleted strip length column in table in Figure 1 and placed information in Figure 1 area
- Deleted Paragraph 2.3 and renumbered
- Deleted Figures 3 and 7 and renumbered
- Changed amperage in Section 3, HOUSINGS